



## 300x300 HERKULES X-CNC 34x1,1

 mm  
300

 a x b  
300x300

 a x b  
300x220

  
3x400V 50 Hz

  
3,0

  
20-100

  
4520x34x1,1

  
1420

Lmin  
2230

Lmax  
2510

Bmin  
1450

Bmax  
2280

H  
1800

V  
800



STANDARD    OPTION

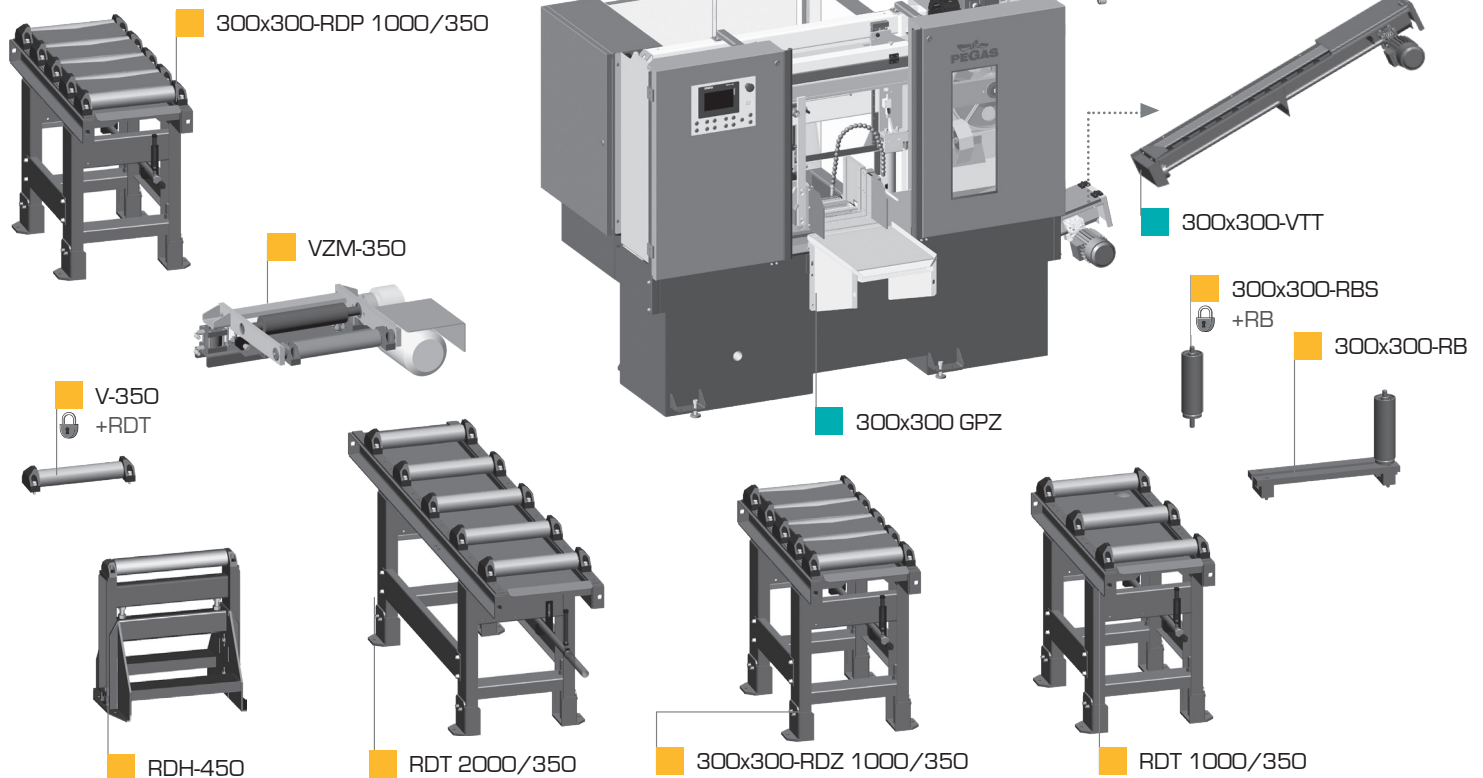
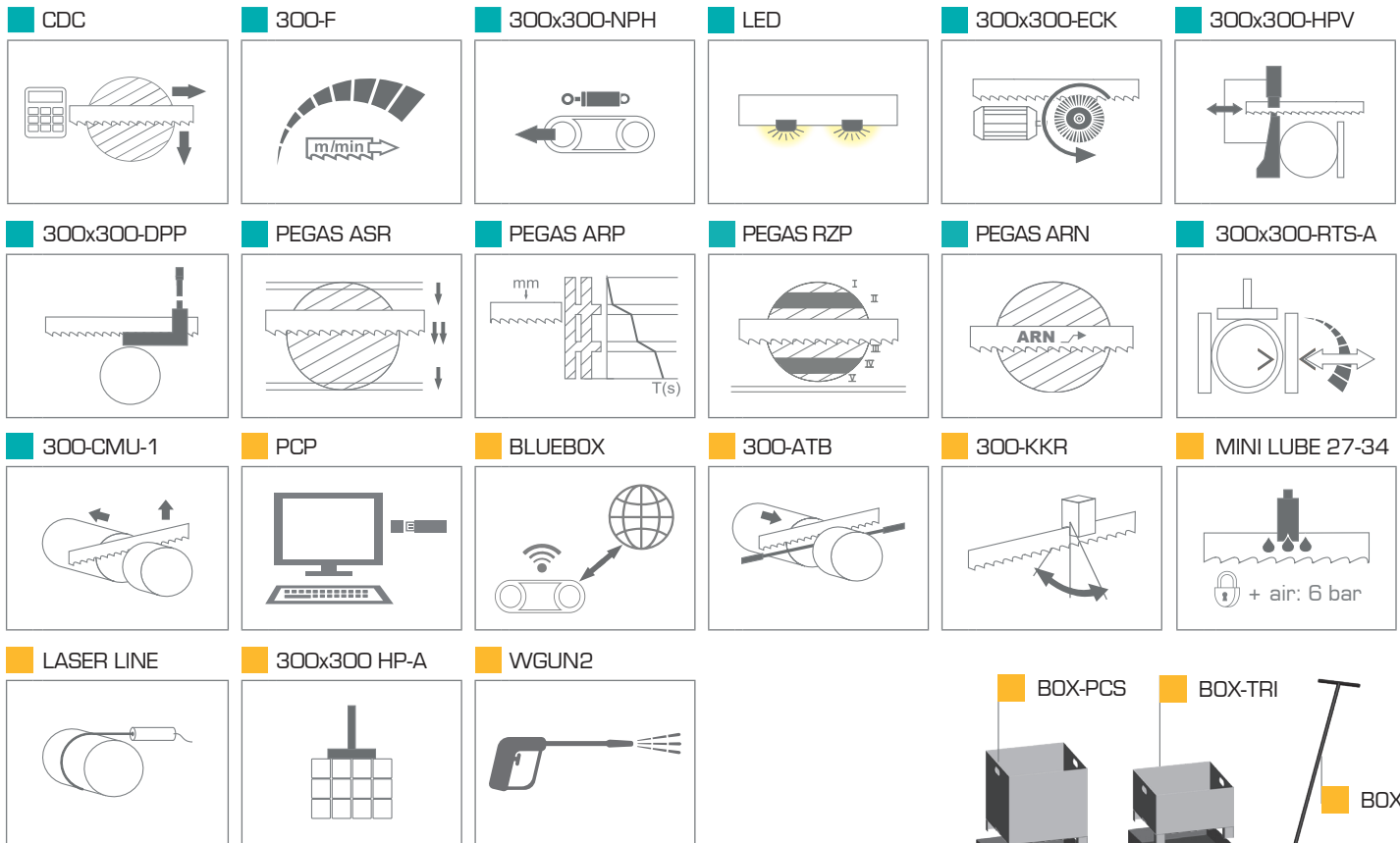

## 300x300 HERKULES X-CNC

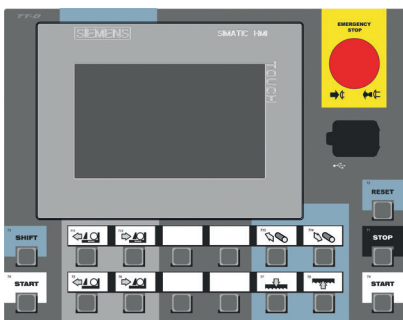

CONTROL PANEL: SIEMENS [X-CNC]

- výrobce si vyhrazuje právo provádět změny technických údajů, technické údaje odpovídají 1.1.2024 / producer has the right to make changes of technical data, technical data are valid on 1.1.2024

- pila na fotografii není vždy v základním provedení, uvedené rozměry odpovídají stroji v základním provedení / the machine in the picture is not always in the basic version, mentioned diameters are for machine in basic version

\* doporučená hodnota. Při překročení doporučeného maximálního průměru není možné garantovat výkon pilového pásu! / recommended value. The blade performance cannot be guaranteed when the recommended diameter is exceeded!

- řezání svazků bez horního přitlaku / cutting of the bundle without top clamping



PEGAS - GONDA s.r.o.  
Čs.armády 322, 684 01 Slavkov u Brna,  
CZECH REPUBLIC

[www.pegas-gonda.cz](http://www.pegas-gonda.cz)  
00420-544 221 125 (126) | [pegas@gonda.cz](mailto:pegas@gonda.cz)